

CHAPTER 1

The fundamental toolbox for analysing the development of a hydrogen economy

Introduction

Hydrogen has long held promise as a clean energy carrier, but its potential remained largely unfulfilled, mostly owing to two fundamental problems: its low density, which makes it hard to handle, and the fact that – contrary to fossil fuels – hydrogen is extremely difficult to isolate from other elements (Alverà 2021). However, due to the ever-growing concerns about the anthropogenic nature of climate change, H₂ has been increasingly regarded as the missing piece of a decarbonised energy system, because of numerous reasons including the following: hydrogen production can be carried out using diverse energy resources and methods (see the next paragraph); H₂ does not emit CO₂ at the point of use and upon combustion it produces water (H₂O); it can be used as energy carrier and can also be employed as a fuel for combined heating and power (CHP) production systems; finally, due to the intermittent and non-dispatchable nature of solar and wind (renewable) energy sources, hydrogen can be regarded as a key candidate that can be used as a storage medium, especially for long-term renewable energy storage (Ishaq et al. 2022).

A true decarbonisation of national energy systems is however possible only if both final uses and the entire energy supply chain are emission-free. Therefore, in this case, a comprehensive life-cycle assessment of hydrogen delivery is necessary. That is why the first section of this chapter will be devoted to evalu-

Francesco Gabrielli, francesco.gabrielli1@edu.unifi.it, 0009-0002-9298-3229

Referee List (DOI 10.36253/fup_referee_list)

FUP Best Practice in Scholarly Publishing (DOI 10.36253/fup_best_practice)

Francesco Gabrielli, *The fundamental toolbox for analysing the development of a hydrogen economy*, © Author(s), CC BY 4.0, DOI 10.36253/979-12-215-1013-3.03, in Francesco Gabrielli, *The Multi-Purpose Nature of Hydrogen for Decarbonising the European Energy System. Integrated Scenarios and Future Challenges*, pp. 11-43, 2026, published by Firenze University Press, ISBN 979-12-215-1013-3, DOI 10.36253/979-12-215-1013-3

Book References DOI 10.36253/979-12-215-1013-3.references

ating and comparing the different hydrogen production methods, both from a technical and a cost-effectiveness point of view. Before deepening the technological aspects related to H₂ generation, it is important to mention the so-called «hydrogen colour spectrum» (National Grid 2022) that has been progressively established in the literature as the primary methodology to classify the renewability of the sources from which H₂ is produced. The colours used to identify fossil-based hydrogen generation are four: black (or brown), grey, blue, and turquoise. The first colour represents H₂ production from coal (or lignite), resulting in high levels of CO₂ and carbon monoxide that are released in the atmosphere. Grey hydrogen is usually produced from natural gas via steam methane reforming (SMR), which will be thoroughly explained in the next section, since it is currently the most exploited technology, but also one that generates around 11 tonnes of CO₂ for every tonne of hydrogen produced (Alverà 2021). Blue hydrogen instead, despite being sourced from fossil fuels (mainly methane), is coupled with a system that captures the emitted CO₂, which is then often stored (Carbon Capture and Storage, CCS) or sold and used in other industries (Carbon Capture and Utilisation, CCU). The fourth colour identifies a method that is still in an experimental stage and involves the breakup of methane molecules (CH₄) in their constituent parts, namely hydrogen and solid carbon, following the heating up of methane in the absence of oxygen. Methane cracking therefore does not result in CO₂ emissions, but temperatures between 800 and 1200°C (and thus a lot of energy) are needed to split CH₄ due to its high stability (Alverà 2021). The remaining colours of the spectrum that identify the way in which hydrogen is produced are pink (or red/purple) and green. While the former uses nuclear power (either in form of heat or electricity produced by the power plant) to produce H₂, green hydrogen is generated through the water electrolysis process by employing renewable electricity, thus avoiding CO₂ emissions during production¹.

After the techno-economic assessment of hydrogen production methods in the first section, the second section of this chapter will deepen a critical component of the hydrogen economy, namely transmission and storage systems. The main routes of hydrogen transport that are currently under development and that will be analysed are: repurposed gas networks, newly built H₂ pipelines, and more flexible (road, rail, river and maritime) transportation networks. The choice of the most effective delivery method depends on the chosen means of storage, as changes in the state of hydrogen increase energy losses, delivery distance, and throughput (Reuß et al. 2017; Yang and Odgen 2007). Finally, the third section of this chapter will address hydrogen final uses, that cover a broad range of applications, from the heavy industry sector to residential heating and

¹ A 2023 IEA report has put forward a proposal to abandon the hydrogen «colour codes» and to adopt a new methodology to define the different hydrogen production processes based on their emission intensity, because the agency argues that the use of colours or terms such as «clean» and «low-carbon» can obscure many different levels of potential emissions and deter potential investors from hydrogen projects (IEA 2023).

CHP units, which are increasing in importance in decentralized energy systems (Weidner et al. 2019). In many of the «hard-to-abate» industries (chemical, steel, cement), hydrogen (mostly in its “grey” form) is mainly used not as an energy carrier but as a feedstock.

Two final aspects should be considered before examining the different components of the hydrogen economy. The first concerns the safety of using H₂, since most hydrogen hazards relate to the fact that, like methane, hydrogen gas cannot be spotted with human senses (Rigas and Amyote 2013), even though leaks can be detected thanks to the addition of odorants to the gas. On the other hand, unlike gasoline, hydrogen is neither toxic nor carcinogenic (Linde AG 2018). The second aspect is related to H₂ utilisation and particularly to the willingness to pay of consumers for using hydrogen-based technologies (such as in transport or heating). According to economic theory, a customer purchases a product or service if two main conditions are met: 1) the utility provided by the good exceeds the so-called total cost of ownership (TCO), that is, its net utility is positive, and 2) if the product’s net utility is the highest among all available alternatives (Hafner and Luciani 2022). In this case, the reduction of CO₂ emissions incurred in using hydrogen-based technologies may raise the perceived utility of the product, while the TCO depends on the dimension of fixed and variable costs (such as for example the cost of hydrogen fuel for cars).

1.1 Hydrogen generation

The first essential step lies in the selection of the primary energy source for producing hydrogen. The former must first and foremost be reliable and affordable. The current main hydrogen production method is through fossil fuels (around 95-96% globally) and more specifically natural gas reforming (also called steam-methane reforming, SMR), methane partial oxidation and coal gasification (Ishaq et al. 2022). Only the remainder 4-5% is produced from water electrolysis, meaning that associated to hydrogen production there are still significant CO₂ emissions. Although such a ratio between electrolytic and fossil-based H₂ has tended to hold steady in recent years, the importance of avoiding carbon-based (and thus polluting) technologies to produce hydrogen has emerged, together with significant concerns regarding the efficiency of carbon removal methods, such as carbon capture, utilisation and storage (CCUS). To this end, we will outline the salient features of the different hydrogen generation methods, whose cost-effectiveness and economic aspects will be addressed thereafter. Finally, we will focus more specifically on the growing attention towards the production of renewable (green) hydrogen.

1.1.1 Hydrogen production processes

A broad range of methods is available for H₂ generation which can be categorized into two primary groups: renewable technologies and non-renewable technologies (Nikolaidis and Poullikkas 2017). The latter category includes hy-

drocarbon pyrolysis and hydrocarbon reforming, which encompasses the three fossil-based methods mentioned above. On the other hand, hydrogen production via renewable energy has two main branches, namely biomass-based and water-splitting technologies. Processes that use biomass as the raw material fall into two further sub-categories: thermochemical technologies such as gasification, pyrolysis, combustion, and liquefaction; and biological processes comprising fermentation and bio-photolysis stages (Nikolaidis and Poullikkas 2017). Water-splitting processes instead include electrolysis, photo-electrolysis, and thermolysis where water is the feedstock. A technical overview of those technologies is provided in the next paragraphs, mainly building on Ahmed et al. (2022).

Fossil-fuel processing technologies

The basic operating principle of such technologies is the extraction of the high hydrogen content of fossil fuels by breaking down the hydrocarbons in different ways. As stated above, these H₂ extractions can occur either by reforming the molecular structure of the compounds or by imposing the thermal decomposition of hydrocarbons at extremely high temperatures (Kumar and Himabindu 2019). Despite the significant amount of emissions, these technologies offer low-cost and easily adaptable alternatives to non-conventional hydrogen extraction mechanisms and above all lead to a significantly higher yield of hydrogen (Ahmed et al. 2022). Hydrocarbon pyrolysis can indeed have a 78% H₂ yield and up to 91% conversion efficiency (Pérez et al., 2021). This process produces hydrogen by thermal decomposition (with temperatures up to 1175°C), where the light liquid hydrocarbons (i.e., methane, ethane, etc.) are decomposed through a thermo-catalytic process that produces elemental carbon and hydrogen.

The partial oxidation technology is instead a conversion process that is used to extract hydrogen and CO₂ as the by-products of steam, oxygen (O₂) and hydrocarbons. If any sulphur is present in the latter element, it is removed initially and then the feedstock (methane) comes into contact with O₂ so that the hydrocarbon becomes partially oxidized. When using coal as a feedstock, this process is also known as coal gasification, whereby pressure and heat break down coal into its chemical constituents, resulting in a synthetic gas mixture, composed mainly of CO and H₂. The produced syngas (CO+H₂) is then treated using steam reformation techniques. The process is very similar to steam reformation technology (see the next paragraph), and the only major difference is the initial oxidization step, while the conversion efficiency can be up to 99% (Fakeeha et al., 2020).

Finally, the steam methane reforming (SMR) process is a well-established technology that includes several stages, such as synthesized gas production, water-gas shift (WGS), and gas purification. Light hydrocarbons and heavy naphtha are used as feedstock, with no requirement for an oxygen source. After the first step involving the de-sulphurisation of natural gas, the actual steam methane reforming takes place, whereby natural gas reacts with steam at high temperatures and forms carbon monoxide and hydrogen gases, according to the following conversion: $\text{CH}_4 + \text{H}_2\text{O} \rightarrow \text{CO} + 3\text{H}_2$. The produced CO can further

be reacted with steam using the water gas shift reactor to convert carbon monoxide into CO_2 and additional hydrogen can be produced: $\text{CO} + \text{H}_2\text{O} \rightarrow \text{CO}_2 + \text{H}_2$ (Ishaq et al. 2022). Since the products of this conversion are mostly H_2 and CO_2 , they are purified using CO_2 removal mechanisms (Nikolaidis and Poullikkas 2017). If carbon capture technologies are not integrated as a final stage in this process, SMR results in large quantities of GHG emissions due to the carbon dioxide produced while extracting hydrogen, thus representing one major drawback of this technique. This notwithstanding, as will be discussed in the economic analysis of H_2 production methods, SMR has drawn the attention of many researchers and policymakers due to its high efficiency in hydrogen production (70 to 85%) with low operational, feedstock ($0.3 \text{ \$/kgH}_2$) and production ($1.25 \text{ to } 3.50 \text{ \$/kgH}_2$) cost (Kannah et al. 2021).

Renewable hydrogen production technologies

Renewable techniques have gathered pace, mostly relying on water electrolysis. The latter is indeed used to split water into its components of oxygen and hydrogen using electricity generated from solar, wind, geothermal, hydro, and biomass energy sources, according to the following reaction: $2\text{H}_2\text{O} \rightarrow 2\text{H}_2 + \text{O}_2$. The relative simplicity of this process leads to focus more on the type of instrument used to perform the water splitting, namely the electrolyser.

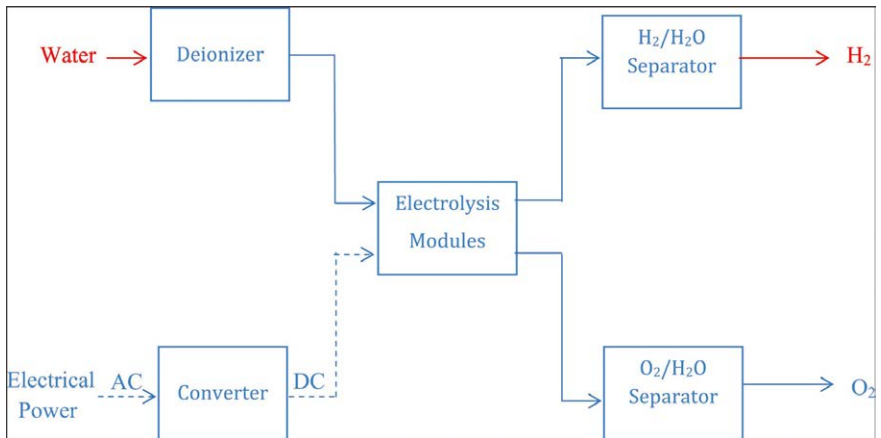

Figure 1 – Flow diagram of the water electrolysis process. Source: Nikolaidis and Poullikkas (2017).

Solar energy can play a significant role in clean and sustainable hydrogen production, not only through photovoltaic generation, but also with solar thermal and photo-electrochemical technologies (Calls et al. 2019). The concentrated solar thermal energy source can be used to produce hydrogen using multiple routes namely, solar thermolysis, solar thermo-chemical cycle, mechanical

energy to electrical energy, solar gasification, solar cracking, and electrolysis (Ishaq et al. 2022). The electrical power produced from the photovoltaic source is instead directly employed to the electrolysis for hydrogen production. As to photo-electrolysis, sunlight in a photo-electrochemical cell is used to produce H_2 from water (Scott 2019).

Wind energy (power produced from the conversion of kinetic energy into mechanical energy through a turbine and finally electrical energy by a generator) is another critical source of green hydrogen. The electrical energy extracted from the wind energy source is alternating current (AC), thus an alternating-direct current (DC) converter is employed to feed the DC electrical power to the electrolyser for hydrogen production (Ishaq et al. 2022). It is important to address the difference between onshore and offshore wind turbines, since their location has significant implications for the generation costs of green H_2 . There are more wind resources on the offshore sites globally in comparison with onshore (approximately twice as medium onshore wind farms), and when sited offshore, the acoustic and visual impact is very trivial, therefore much larger areas can be used (Wang et al. 2019)².

Geothermal energy is transmitted to the earth's surface using steam or hot water and it can be utilized for multiple purposes, such as cooling, heating, or producing electricity (Ishaq et al. 2022). Using this source of energy to produce hydrogen mainly refers to electrical power generated that feeds the electrolyser to split water. But geothermal energy can also be used to heat the water which makes electrolysis more efficient (Soltani et al. 2019) and geothermal heat can be employed for thermochemical hydrogen production (Balta et al. 2010). A geothermal source with a high temperature is required for lower cost hydrogen production and liquidating processes (Ishaq et al. 2022). Another technology that can be exploited to produce green hydrogen is hydropower, which is considered renewable due to the fact that the cycle of water is continuously renewed. However, excluding a few countries that are abundant in this source (such as Norway), hydropower is generally used as a backup to meet the peak-load demand as it can be voluntarily started and stopped, and the energy flows can be concentrated and controlled (Peng et al. 2021).

One final technology that allows to produce hydrogen avoiding net-GHG emissions is biomass gasification. The latter can be defined as a process that converts biomass – such as crop residues, forest residues and solid waste – into syngas ($CO+H_2$) by means of oxygen and/or steam at temperature greater than $700^\circ C$ (Capurso et al. 2022), thus transforming an organic material into carbon monoxide, carbon dioxide and hydrogen. Gasification is a considerably cleaner process of conversion as compared with combustion, because gasification produces fuel

² A recent DNV study has found that offshore hydrogen production connected by pipeline could be cheaper than onshore hydrogen production. Given the expected EU demand for climate-neutral hydrogen at around 2,000 terawatt hours (TWh) by 2050, DNV sees the potential to produce 300 TWh of hydrogen using electricity from offshore wind farms in the North Sea by 2050 (Bernert 2023).

in the form of syngas rather than burning it which prevents many pollutants to be emitted such as nitrogen oxides (NO_x) and sulphur oxides (SO_x) that occur at higher temperatures (Ishaq et al. 2022). The latter elements are combustion products that are emitted in the form of smoke when the temperature is higher than that of gasification, and they have indeed adverse effects on the ozone layer in the troposphere, thus worsening the global warming process. Biomass gasification's efficiency is around 46% (Staffell et al. 2019). Because plants consume carbon dioxide from the atmosphere as part of their natural growth process as they make biomass, they contribute to off-setting the carbon dioxide released from producing hydrogen through biomass gasification, resulting in low net greenhouse gas emissions (US Department of Energy 2019). If combined with a Carbon Capture and Storage (CCS) technology, hydrogen production from biomass gasification could be even carbon negative (Capurso et al. 2022).

1.1.2 Economic assessment of hydrogen production methods

Since hydrogen is not widely accessible in nature, the energy conversion routes highly influence the overall cost of hydrogen production (Ahmed et al. 2022). An analysis of the main cost components involved in the upstream stage of the H_2 value chain is therefore important in order to have a sharper picture of the hydrogen economy. Firstly, cost parameters for H_2 production can be divided into two major categories, which will be also mentioned in the subsequent sections, namely operational (OPEX) and capital (CAPEX) costs. The latter have been sub-divided, by Kannah et al. (2021), into two groups: the direct capital costs, that include instrumentation, control system and site-specific costs, and indirect capital costs, that include engineering and supervision, construction costs, legal and contractor expenses and contingency. Instead, operating costs are represented by the raw material (the feedstock), by labour and maintenance costs. In the next paragraphs, first a definition of «Levelised Cost of Hydrogen» is provided, secondly, the costs of the main hydrogen production methods will be outlined and compared to one another, drawing from the existing techno-economic literature. Thirdly, some important cost parameters of the hydrogen upstream component – such as the Net Present Value (NPV), the Return on Investment (ROI) and the Pay-Back Period (PBP) – will be discussed.

The methodology used to establish the capital and operating costs of hydrogen production is indeed defined as «Levelised Cost of Hydrogen» (LCOH), which enables different production routes to be compared on a similar basis. The LCOH indicates how much it costs to produce 1kg of hydrogen, taking into account all the relevant variables that affect production, namely CAPEX, OPEX and – if renewable electricity is used – the annual hourly production curve of the renewable resource (Vector Renewables 2022). For the purpose of this chapter, it is therefore essential to briefly examine how the LCOH is calculated. Since it is used for evaluating the economic performance of hydrogen production, the LCOH is defined as discounted cash flows divided by the discount hydrogen output, according to the following formula (Tang et al. 2022):

$$\text{LCOH} = \frac{\sum_i \frac{I_i + M_i + O_i - R_i}{(1+r)^i}}{\sum_i \frac{E_i}{(1+r)^i}} \quad (1)$$

where I_i is the investment in year i , M_i the maintenance and service cost in year i , O_i the operational cost in year i , E_i the energy (hydrogen) output in year i , [kg], R_i the revenue income in year i , and finally r is the cost of capital, [%]. If the investment, the other costs and the revenue are taken in euros [€], the LCOH is thus expressed in € per kg of hydrogen [€/kg_{H₂}]. As defined in economic and financial theory, the discounted cash flows are used to find the present value of the expected future cash flows using a given discount rate, so that investors can determine whether future cash flows of a project (in this case related to hydrogen production) are larger than the value of the initial investment. This is the concept of the net present value (NPV). Drawing from the formula described above, since the aim is to investigate the cost components, the cash flows and the hydrogen output are simplified as constants along with the years, thus resulting in the following equation (Tang et al. 2022):

$$\text{LCOH} = \frac{(I + M + O - R) \sum_i \frac{1}{(1+r)^i}}{E \sum_i \frac{1}{(1+r)^i}} = \frac{(I + M + O - R)}{E} \quad (2)$$

To have a first practical outlook of the evolution of the LCOH on a global level, the IEA has provided a chart (Figure 2) that reports the actual LCOH in 2021 and 2022, versus the expected LCOH for 2030, based on the path to climate neutrality by 2050, for different production sources.

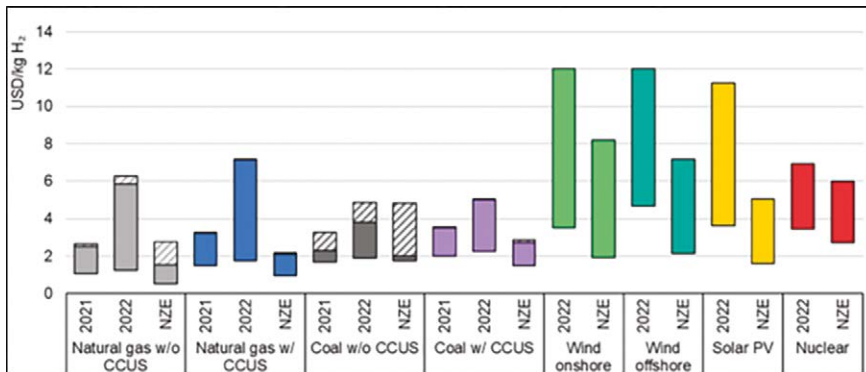

Figure 2 – Levelised cost of hydrogen production by technology in 2021, 2022 and the Net Zero Emissions by 2050 Scenario [\$/kg_{H₂}]. Source: IEA (2023c). Notes: CCUS = carbon capture, utilisation and storage; PV = photovoltaic; NZE= Net Zero Emissions by 2050 Scenario in 2030. Solar PV, wind and nuclear refer to the electricity supply to power the electrolysis process. NZE values refer to 2030. The dashed area represents the CO₂ price impact.

The LCOH shows a high variability depending on the hydrogen production source. When using natural gas, it can be seen that costs are comparatively lower than when using renewable technologies. The spikes in the 2022 LCOH for natural gas (both with and without CCUS) are mainly due to the gas price crisis sparked by Russia's war against Ukraine in early 2022 and the already present tightness in gas markets from late 2021. All costs are projected to be declining by 2030 compared to 2022, but wind- and solar PV-based H₂ production will remain costlier than the fossil-based one also in the medium term, even though prices will be lower overall compared to today.

Since in the following we will review the literature assessing H₂ generation costs according to each technology, one last element should be mentioned in this first part, because it will also be useful to better understand the next chapters, which will be dealing with the integration of electricity and hydrogen molecules. The LCOH's calculation methodology can indeed be compared to the technique used to compute the so-called «Levelised Cost of Electricity» (LCOE), which – being always linked to the concept of the present value of the investment – is calculated by the net present value (NPV) of the total cost of building and operating a power generating asset, and dividing this number by the total electricity generation over the lifetime of the plant (US Department of Energy 2013). The LCOE is therefore the measure of lifetime costs of the power plant divided by its energy production, thus allowing for comparisons of different technologies (solar, wind, natural gas...) with unequal life spans, different CAPEX, different risks and returns. As will be mentioned later in this chapter, one of the current most significant challenges in increasing the size of the hydrogen economy and scaling-up green hydrogen production lies in reducing the cost of the electrolyser, since the H₂ production cost is greatly influenced by the electrolyser capital cost, and the maximum electrolyser utilisation (load hours) results in lower H₂ production costs, which accounts about 3000-6000 operating hours (Kannah et al. 2021).

The latter element is one of the main reasons why steam-methane reforming (SMR) is still the most widely used technology for H₂ production, since its high efficiency leads to larger hydrogen yield per unit of feedstock, resulting in a production cost that lies between \$1.25 and \$3.50 (or €, given today's quasi-parity of the two currencies) per kg of H₂. As SMR leads to significant CO₂ emissions, carbon capture and storage (CCS) technologies are used and therefore the cost of H₂ production can increase, being no less than 2.27 \$/kg_{H₂} (Nikolaidis and Poullikkas 2017). Coal gasification lies between 1.30 and 1.60 \$/kg_{H₂} (Ahmed et al. 2022). Such methods of thermo-chemical conversion are thus extensively exploited due to the energy density and huge availability of carbon-based fuels. Indeed, on a global level, approximately 48% of H₂ is produced from natural gas, 30% using oil and 18% using coal.

Renewable hydrogen produced through water electrolysis shows, instead, higher costs per kg. For instance, Kuckshinrichs et al. (2017) documented the economic analysis of mature H₂ production technology (Alkaline water electrolysis, AWE) at three different site locations in Europe – Germany, Austria, and Spain. They reported that the LCOH was around 3.64 €/kg_{H₂} at the German site, whereas in Austria and Spain sites, the levelised cost of H₂ was slightly higher (15 to 18%),

mainly owing to the higher electricity cost. Matute et al. (2019) have estimated the cost of H_2 production for AWE around 6 €/kg $_{H_2}$ and Proton-exchange membrane (PEM) based water electrolyser as 7 €/kg $_{H_2}$. According to Ahmed et al., (2022), photo-electrolysis with a solar energy source can have a production cost as high as 10.36 \$/kg $_{H_2}$, and a similar pattern is also followed by the H_2 production technologies using biomass (lignocellulose in this case), whose cost lies around 12 €/kg $_{H_2}$. Table 1 gives a schematic overview of the above-mentioned data.

Table 1 – Costs of hydrogen production using available technologies. Source: own elaboration based on selected studies.

Technology	LOHC [\$ & €/kg $_{H_2}$]	Study
Steam-methane reforming	1.25-3.50	Ahmed <i>et al.</i> (2022)
SMR with Carbon Capture and Storage (CCS)	2.27	Nikolaidis and Poullikkas (2017)
Coal gasification	1.30-1.60	Ahmed <i>et al.</i> (2022)
Renewable hydrogen (water electrolysis using ALK and PEM electrolysers)	3.64 (Germany ALK), ~5 (Austria, Spain ALK), ~6 (ALK), 7 (PEM)	Kuckshinrichs <i>et al.</i> (2017) Matute <i>et al.</i> (2019)
Renewable hydrogen (photo-electrolysis)	10.36	Ahmed <i>et al.</i> (2022)
Biomass technologies	12	Ahmed <i>et al.</i> (2022)

Because green hydrogen is mostly produced via electrolysis, it is interesting to briefly focus on the way in which production (fixed and operating) costs for water electrolysis are formed, so as to have the necessary theoretical instruments to analyse the next section covering renewable hydrogen in particular. The factors that determine the CAPEX, the OPEX and the mass of hydrogen produced (M_{H_2}) can be specified as follows (Kannah et al. 2021):

$$CAPEX = CCA + (OMC + IC) \cdot CCA \cdot A \quad (3)$$

$$OPEX = COE \cdot \frac{r_{H_2} \cdot HHV}{\eta} \cdot LT \cdot CF \quad (4)$$

$$MH_2 = r_{H_2} \cdot LT \cdot CF \quad (5)$$

where CC_A = capital cost of electrolyser, A = net area of the electrode (used to split water), COE = cost of electricity, r_{H_2} = rate of H_2 production, HHV = higher heating value of hydrogen³, η = efficiency of the electrolyser system, LT = lifetime

³ The heating value (or energy value or calorific value) of a substance is the amount of heat released during the combustion of a specified amount of it. The calorific value is thus the total energy released as heat when a substance undergoes complete combustion with oxygen un-

of the electrolyser, CF = capacity factor⁴, OMC = operation and maintenance costs, IC = installation costs, and CC_A times A = total capital cost. The cost of electricity is one of the most critical elements for establishing the convenience of the whole electrolysis system, and also the water supply must be considered. Electricity cost is strictly connected to the concept of power purchase agreements (PPAs). These are increasingly used contracts signed between a producer and a consumer of electricity that fix a certain price, thus insulating the counterparts from market price volatility. For instance, Fragiaco and Genovese (2020) include PPAs to calculate the electricity cost in their economic analysis of renewable hydrogen production in southern Italy⁵.

Before moving to the analysis of renewable hydrogen replacing fossil-based H_2 , one last point should be made with regard to the methods used to establish the cost-effectiveness of a hydrogen production technology. Return on investment (ROI) and the pay-back period (PBP) will be briefly addressed. While the latter can be defined as the time, in years, that the expected benefits of the investment equal the fixed assets, namely when the NPV is equal to zero, the ROI index represents the potential economic returns compared to the initial investment (Fragiaco and Genovese, 2020). Therefore, ROI can allow to identify the total growth of the production plant from the start to the end of its life. Kannah et al. (2021) present the following formula to calculate ROI: $ROI = (AF/FCI) * 100\%$, where AF is the annual profit (difference between annual revenue and annual production cost) and FCI is fixed capital investment (cost required for purchase of land, equipment and installation). Typically, a value of ROI above 20% is considered as profitable for the scaling up process.

1.1.3 Renewable hydrogen substituting polluting hydrogen production methods

Renewable hydrogen, as outlined by the EU Hydrogen Strategy (2020) is defined as «hydrogen produced through the electrolysis of water (in an electrolyser, powered by electricity), and with the electricity stemming from renewable sources», adding that «the full life-cycle greenhouse gas emissions of the production of renewable hydrogen are close to zero» (European Commission

der standard conditions. The higher heating value (HHV) - or gross energy, upper heating value, gross calorific value GCV, or higher calorific value - indicates the upper limit of the available thermal energy produced by a complete combustion of fuel. It is measured as a unit of energy per unit mass or volume of a substance. The HHV is determined by bringing all the products of combustion back to the original pre-combustion temperature, and in particular condensing any vapor produced. See: Wikipedia Contributors (2019). *Heat of combustion*. [online] Wikipedia. Available at: https://en.wikipedia.org/wiki/Heat_of_combustion.

⁴ The capacity factor can be defined as the ratio of the net electricity generated, for the time considered, to the energy that could have been generated at continuous full-power operation during the same period (U.S. NRC 2021)

⁵ The role of PPAs is currently also being enforced in the context of the reform of the electricity market design at the European Union level (see the next chapters).

2020)⁶. The newly adopted EU Delegated Acts on Renewable Hydrogen further specify that unless the electricity system is already largely decarbonised, it is crucial to match the electricity demand for hydrogen production with additional renewable electricity generation, otherwise electrolyser's additional electricity demand could risk leading to increased fossil-based power generation (European Commission 2023).

Therefore, using «clean hydrogen» as a synonym for renewable H₂, it is important to introduce the concept of «well-to-gate» when accounting for emissions in hydrogen production. This is an assessment methodology that calculates the lifecycle emissions associated with upstream feedstock production, upstream transportation, and onsite hydrogen production, thus excluding downstream storage and transport emissions, service and end-of-life emissions, and it can be measured in grams or kilos of CO₂ equivalent per kg of produced hydrogen (Connell 2022). For instance, the well-to-gate GHG emissions of steam reforming of natural gas are about 9 kg of CO_{2eq}/kgH₂, while those of SMR with carbon capture and storage (CCS) with 90% capture are equal to 1 kg of CO_{2eq}/kgH₂, and 4 kgCO_{2eq}/kgH₂ with a capture rate of 56% (IEA 2019).

Several obstacles must be considered when assessing the increasingly wider employment of renewable hydrogen and the flexibility that the latter can provide to decarbonise polluting sectors of the economy. The first key component is renewable electricity, which when produced through solar PV or wind can also be referred to as variable renewable energy (VRE). Hydrogen produced from renewable electricity (through an electrolyser) could indeed facilitate the integration of high levels of VRE into the energy system, because the electricity consumption of electrolysers can be adjusted to follow wind and solar power generation, where hydrogen becomes a source of (long-term) storage for renewable electricity (IRENA 2018). Moreover, hydrogen from renewable electricity could create a new downstream market for renewable power, because it has the potential to reduce renewable electricity generators' exposure to power price volatility risk, in instances where part or all generation is sold to electrolyser operators through long-term contracts (e.g. PPAs). The second key element is thus the electrolyser, analysed hereafter.

Scaling-up electrolysers to reduce the cost of green hydrogen

The measures taken by several governments and by the EU to set manufacturing capacity targets for electrolysers are increasingly coupled with financial incentives to expand production, but electrolysers deployment – and thus the supply of

⁶ Hydrogen produced from biomass (through biogas) is also considered renewable by the Renewable Energy Directive (2018), but it is not included in the definition of «Renewable fuels of non-biological origin» (RFNBOs) as included by the European Commission in the «Additionality Delegated Act», formally adopted in June 2023, because biomass is defined as «the biodegradable fraction of products, waste and residues from biological origin from agriculture, including vegetal and animal substances, from forestry and related industries, including fisheries and aquaculture, as well as the biodegradable fraction of waste, including industrial and municipal waste of biological origin» (Renewable Energy Directive 2018).

renewable H_2 – will be eventually determined by the demand for green hydrogen. According to the International Renewable Energy Agency (2021), cost declines in electrolyser manufacturing are greatest during the current, early stage of deployment, when the cumulative capacity deployed is still small and the market is relatively concentrated in a few companies. On the other side, however, current costs suffer from lack of transparency, due to the nascent stage of the industry, which will likely be resolved as large-scale manufacturing facilities come online and large projects get commissioned (IRENA 2021). By considering figure 3, which reports the planned investments (in GW/year) in electrolyser manufacturing capacity between 2021 and 2030, it is clearly visible that Europe and China have got the largest share in planned capacity, thus aiming to exploit economies of scale.

Before focusing on the specific cost reduction strategies, it is important to illustrate the main features of the existing electrolyser technologies, drawing from a detailed report published by IRENA (2020). Electrolysers can be distinguished in four categories, two of which are fully mature or rapidly emerging (ALK and PEM), and the other two can be promising technologies in the medium term (SOEC and AEM). ALK (which stands for alkaline) electrolysers have a simple system design and are relatively easy to manufacture, having electrode areas up to 3 m^2 . There are indeed two electrodes (anode and cathode) in an electrolyser, which are contained in a cell, that is the core of the machine. This type of electrolyser has been used since the 1920s for non-energy purposes mainly in the chemical industry. On the contrary, the rapidly growing PEM (proton exchange membrane) electrolyser technology uses electrodes with advanced architecture that allows them to achieve higher efficiencies, thus operating more flexibly and reactively than current ALK technology and have a shorter response time (NREL 2016a; NREL 2016b). SOEC (solid oxide) electrolysers hold the promise of greater efficiencies compared to ALK and PEM, being however a less mature technology, SOEC can potentially be a game-changer in the medium term. Finally, AEM (anion exchange membrane) electrolysers are the latest model, with limited deployment but a potential that lies in the combination of a simpler environment, from alkaline electrolysers, with the efficiency of a PEM electrolyser. Alongside efficiency, the CAPEX of the electrolyser is another important parameter to take account of. For the purpose of this chapter, two main capital cost estimations are outlined, for the two most developed technologies, ALK and PEM.

According to Proost (2019), capital costs by 2020 lied between 800 and 1300 €/kW for alkaline, and between 1000 and 1950 €/kW for PEM systems, and by 2030, these costs are estimated to be only slightly lower than in 2020, being in the range 700-1000 €/kW and 850-1650 €/kW for alkaline and PEM, respectively, as summarised in Table 2. It is important to keep in mind that the global installed capacity of water electrolysis for H_2 production has remained in the megawatt-scale. Only at the end of 2022 the total electrolyser capacity reached around 1.4 GW, which nonetheless represents an almost threefold increase compared to the 513 MW of installed capacity in 2021, that in turn represented a nearly 70% increase compared with 2020 (304 MW), according to the IEA (2022).

Table 2 – Capital costs of ALK and PEM electrolyzers in 2020 and 2030 (€/kW). Source: own elaboration from Proost (2019).

Electrolyser technology	Cost in 2020	Cost in 2030
Alkaline (ALK)	800-1300	700-1000
Proton exchange membrane (PEM)	1000-1950	850-1650

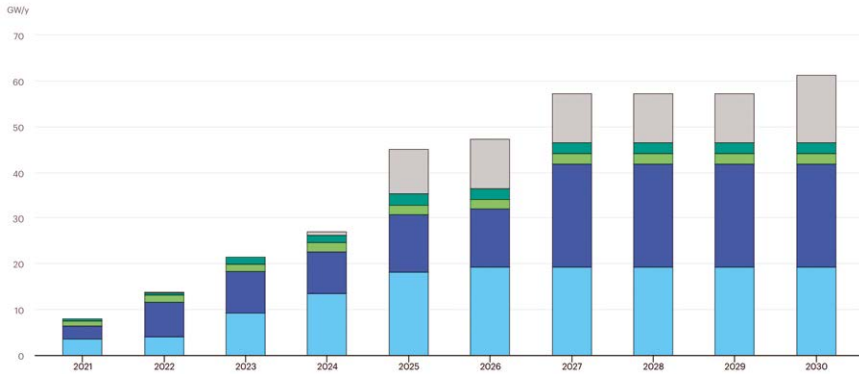

Figure 3 – Planned electrolyser manufacturing capacity by region, 2021-2030 [GW/year]⁷. Source: IEA (2022).

Depending on the country or area where water electrolysis must be carried out, there can be a barrier to the large-scale deployment of electrolyzers determined by the supply of critical materials used in this technology. For instance, solid oxide electrolyzers, which have the potential for much higher efficiencies and market development, depend almost exclusively on China for around 95% of their critical materials, such as zirconium (Zr), gadolinium (Gd), lanthanum (La), yttrium (Y) and many others (IRENA 2020). Van Berkel et al. (2020) outline three strategies to reduce this dependence on critical materials: 1) prevention or reduction of use implies the substitution of materials, reducing their amount per unit of installed capacity, or varying the technology mix to achieve a lower use overall; 2) extension of the use of equipment includes achieving a higher productivity with less material per kilogram of hydrogen, or extending the lifetime of the electrolyser (i.e. the same amount of material allocated over greater production); and 3) recycling.

Strategies for electrolyser cost reduction

As a final item, the main cost reduction strategies for widening the deployment of electrolyzers should be outlined. The largest benefits for economies of

⁷ From the bottom up in each column: Europe, China, North America, India, Unspecified.

scale for electrolyser manufacturing seem to be reached around the 1 GW/year level (IRENA 2020). Between 2022 and the first part of 2023, several important players in the energy transition announced the construction of so-called «giga factories» to produce electrolysers, such as the project announced in Italy by the electrode manufacturer company De Nora and the national gas transmission system operator SNAM, which formed a joint venture to build a 2GW electrolyser factory (Collins 2023), or the new plant in Spain announced by energy company Iberdrola and US company Cummins at the end of 2022 (Trendafilova 2022).

Two main strategies can be identified to reduce the cost of producing such a technology. Increasing the manufacturing scale of the electrolyser can have a positive impact on its specific cost, while decreasing the cost contribution of buildings, improving the utilisation of equipment (more volume produced from each unit), and reducing losses (IRENA 2020). The second strategy is defined by IRENA (2020) as «learning-by-doing», and it is related to the learning curve (or learning rate), that indicates the percentage decrease in production costs as installed capacity for a given technology doubles⁸. This decline in costs is driven by competition between firms in the market and is complemented by innovation powered by research. Larger deployment leads both to more experience (learning) from multiple projects and to lower risk perception by financial institutions, which results in lower cost of debt and lower investment costs (IRENA 2020).

1.2 Hydrogen transportation and storage

A critical component of the decarbonisation effort is constituted by the establishment of a cost-effective hydrogen transportation and storage system, in order to take full advantage of hydrogen as a clean energy carrier. This section aims at outlining the H₂ delivery and storage options currently under development and which have been subject to in-depth analysis both by industry and policymakers. The technical and economic assessments carried out in the next paragraphs will mainly refer to EU-commissioned studies and evaluations. Therefore, estimations on investment and cost parameters of the concerned infrastructures will reflect the EU's energy system configuration⁹.

We will first analyse the different forms in which hydrogen is made suitable for transportation, and an overview of the main techno-economic aspects of the relevant transport infrastructures will follow. Before moving to this discussion, it is

⁸ The learning rate is an important indicator of the competitiveness of renewable energy technologies, such as solar and wind, which according to Statista (2023) have a learning rate of 23% and 12% respectively, while IRENA (2020) estimated that the electrolyser learning rates will be around 13% for PEM and 9% for ALK between 2020 and 2030.

⁹ The EU Hydrogen Strategy recognises the important role that the transport of hydrogen will play in enabling the penetration of renewable hydrogen in Europe, and especially after 2025 there will be a need to deploy an EU-wide infrastructure to supply hydrogen, therefore a pan-European hydrogen grid will need to be planned (Cebolla et al. 2022). This aspect will be addressed specifically in the second chapter of this work.

worth mentioning that the literature provides for several different classifications of the hydrogen transmission component. For instance, Ishaq et al. (2022) group the hydrogen transportation supply chain for potential future ramp-up into four categories: on-site, semi-centralized, centralized, and intercontinental modes of hydrogen transportation. In a JRC research paper, the hydrogen delivery chain is instead divided into three main segments: the «packing», where hydrogen is prepared for its transport; the transport itself; and the «unpacking», where hydrogen is prepared for its final use (Ortiz Cebolla et al. 2022). Similarly, a study commissioned by the Directorate-General for Energy of the European Commission differentiates between a conversion component (compression, liquefaction, etc.), transmission and distribution components (long-distance transport infrastructure and local distribution network) and inter-seasonal and intra-day storage capacity (European Commission 2021). It is therefore essential to underline that – due also to the uncertainty of future hydrogen demand (and thus of transport needs) in each country – the technical architecture of the hydrogen transport infrastructure is highly context-dependent (Palovic and Poudineh 2022)¹⁰.

1.2.1 Making hydrogen suitable for its transportation

As regards the issue of transportation, five forms of H₂ are considered: compressed hydrogen (CGH₂), liquefied hydrogen (LH₂), ammonia (NH₃), methanol (MeOH), and Liquid Organic Hydrogen Carriers (LOHC). While the first two forms involve only the presence of hydrogen, the last three can be defined as «chemical carriers», since H₂ is mixed with other elements, making it suitable for being transported. Given that these technologies not only allow for the transport of hydrogen, but also for its storage (ENTSO-G et al. 2021), the same classification is used for discussing H₂ storage.

Compressed hydrogen (CGH₂)

Since hydrogen has a low volumetric density, it can be compressed so as to increase its density, thus reducing the volume necessary for its storage and transport. Therefore, the higher the pressure the higher the density of the hydrogen, but also the more is the energy required for its compression up to the chosen final pressure (Cebolla et al. 2022). Hydrogen compression costs depend both on the technology and the pressure, but also on the flow-rate, which is defined as the quantity of fluid (hydrogen in this case) that is passing through a cross-section of a pipe in a specific period of time¹¹. According to the U.S. Depart-

¹⁰ Hydrogen infrastructure - like electricity and natural gas infrastructure - is colour-blind, in the sense that hydrogen compressors (used to efficiently transport and store hydrogen from its point of production to end-use), for instance, do not «see» the H₂ production method colour, as every process produces the same low molecular weight hydrogen gas.

¹¹ The flow rate, or the amount of fluid that flows in a given time, is usually measured in [Sm³/day] for natural gas, but for hydrogen it can be measured in [kgH₂/h] (Ghadban 2021).

ment of Energy¹², the capital costs of compressors delivering hydrogen with a pressure of around 10 MPa (megapascal) and a flow-rate of 8300 kgH₂/h are about \$6 million.

Liquefied hydrogen (LH₂)

Liquefaction plants are used to liquefy hydrogen, whose liquid state requires a temperature of -253°C, involving severe technical challenges to carry out such operation. In its liquid state, nonetheless, hydrogen's density is 2.3 times higher than that of compressed H₂, thus allowing more molecules to be transported using less space (Cebolla et al. 2022). While the capital investment for a liquefaction plant is around \$2.5 to 5 million per tonne of H₂ per day (Connelly et al. 2019), the overall cost is mostly driven by OPEX (high energy cost of liquefaction), but prices could be brought down to 50% by scaling up capacity, which today ranges between 4 and 10 tonnes_{H₂}/day for a conventional liquefaction plant in Europe (Cebolla et al., 2022).

Ammonia

Besides being an essential component in fertilizer production, ammonia (NH₃) is a chemical commodity traded on a global scale, whose production capacity has been steadily growing. European ammonia production is in the order of 20 Mt/yr (Dolci 2018). This chemical carrier is usually produced by reacting hydrogen (ideally supplied by electrolyzers) and nitrogen at high temperatures (400-550°C), and when hydrogen is needed at the arrival site, ammonia is cracked, involving subsequent hydrogen purification steps (Cebolla et al. 2022). NH₃ is regarded as one of the key elements for the creation of a wider hydrogen transport market, since it can be liquefied and kept at around -30°C, thus requiring less energy and being easier to ship. Indeed, ammonia currently accounts for about 40% of global hydrogen demand with around 31 Mt of H₂, of which 80% is used for fertilisers (Breitschopf et al. 2022).

Methanol

Like ammonia, methanol can be used both as an industrial feedstock and as a chemical carrier. Almost the whole European production of methanol is located in Germany (Boulamanti and Moya 2017), and it is conventionally based on syngas (CO+H₂) followed by methanol synthesis (Cebolla et al. 2022). Another solution consists of CO₂ hydrogenation: the latter is a chemical reaction between molecular hydrogen and another compound or element (CO₂ in this case), using a catalyst.

¹² Available at: <https://www.energy.gov/eere/fuelcells/doe-technical-targets-hydrogen-delivery>.

Liquid Organic Hydrogen Carriers (LOHC)

The last chemical carrier to be analysed is constituted by a series of molecules able to release or accept hydrogen, being easy to handle at room temperature and atmospheric pressure, and having physical properties similar to fossil fuels, therefore allowing for the use of existing infrastructure for transport (Cebolla, et al. 2022). According to the European Union Agency for the Cooperation of Energy Regulators (2021), every unsaturated compound (that can be found in crude oil and refined petroleum products) can take up hydrogen during hydrogenation (see above). Together with ammonia, LOHC can have lower costs by 2030 (around \$2-2.5 \$/kgH₂) compared to liquefied hydrogen (2 to 3.7\$/kgH₂), according to the IEA (2023).

1.2.2 Critical infrastructures for building a hydrogen economy

Repurposed gas networks

A brief analysis of the economics of gas transportation by pipeline is necessary to understand the challenges of hydrogen delivery using existing infrastructure. The essential components of such a transportation system are pipes and compressors, since gas moves through pipelines as a result of a pressure differential (from high to lower pressure points), which is created by compressor stations that are generally built every 100 to 500 km along the length of the pipeline (Natgas 2013). It is also important to consider the different types of pipelines based on where they are used: gathering pipelines collect raw natural gas from production fields and connect it to the mainline transmission grid; transmission pipelines (up to about 120 cm in diameter) move gas through long distances (thus at high pressures); distribution pipelines (up to around 25 cm in diameter) deliver natural gas to small industrial plants and customers at lower pressure (2-10 bar or 0,2-1 Mpa); finally, service lines (up to 5 cm in diameter) deliver gas to residential customers at a pressure of 1 bar (Natgas 2013).

From an economic point of view, the most cost-efficient pipeline system design (both CAPEX and OPEX) must consider that length and terrain are external and thus fixed factors. The endogenous components that must be taken into account are linked to several dimensions: the quantities (of gas) to be transported, based on actual or expected demand; the diameter of the pipe (which is inversely correlated with the need for compressors along the line); the maximum allowable operational pressure (MAOP), that is in a trade-off with the thickness of the pipeline's walls; the velocity of the flow, usually up to 72 km/h to prevent pipe erosion; and finally the capacity of compressor stations, that influence OPEX (Hafner and Luciani 2022).

Repurposing natural gas pipelines for hydrogen transportation entails several challenges and technical issues. According to the European Union Agency for the Cooperation of Energy Regulators (ACER 2021), the latter can include embrittlement (and subsequent degradation) of the steel which pipelines are made of, since H₂ molecules can infiltrate and cause cracks resulting in pipe-

line failure¹³. Therefore, not only further costs must be added for adapting the pipes with a layer of internal coating (to chemically protect the steel layer) to allow pure hydrogen to flow, but this gas also needs greater compression (approximately 3 times more compared to methane) in order to achieve a similar energy flow (ACER 2021). Finally, maintenance and monitoring of the pipelines' quality would need to be enhanced to inhibit hydrogen embrittlement (Cerniauskas 2020).

Newly built hydrogen pipelines

Besides the purely technical challenges involved in repurposing natural gas pipelines, during such an activity the supply of methane to customers would nonetheless need to be ensured continuously. Therefore, instead of converting all existing lines, completely new hydrogen pipes can represent an alternative to repurposing, while natural gas ones remain operational to ensure security of gas supply. The design, construction, and operation of H₂ pipelines are however more challenging than most other fluids, also due to safety risks associated with hydrogen's large flammability range in air and invisibility of the flame (Khan et al. 2021). It is important to underline that there can be a significant difference between hydrogen transportation in transmission and distribution pipelines, because high-strength steels that are more often used in natural gas transmission pipelines are more susceptible to H₂ embrittlement (Khan et al. 2021). This in turn means that the lower-strength steel of distribution pipelines (which have a lower pressure) is more suitable for hydrogen pipelines. GRTGaz – the main transmission system operator in France – noted indeed that French regional networks with smaller diameters of steel pipes and with lower yield strength are less sensitive to hydrogen embrittlement compared to larger transmission pipelines, which are more likely to be made of technologically more advanced types of steel (GRTGaz 2019). On the other side, the use of lower grade steel means only lower operating pressures are possible or that the wall thickness will need to be increased to accommodate the high operating pressures of future hydrogen transmission pipelines (Khan et al. 2021).

Road, rail, river, and maritime transportation networks

At present, compressed hydrogen gas is mostly transported by road, using systems known as multiple-element gas containers (MEGCs), consisting of bundles of gas cylinders, that are either metallic or made of a combination of internal liner (metallic or plastic) wrapped with a carbon fibre-based composite material (Cebolla et al. 2022). These containers are usually mounted on trucks, enabling the transport of smaller quantities of hydrogen gas (or liquid H₂ by means of in-

¹³ Hydrogen embrittlement can be technically understood as a metal's loss of ductility and reduction of load-bearing capability due to the absorption of hydrogen atoms or molecules by the metal (ENTSO-G et al. 2021).

sulated tanks) in the range of 1 to 4 tonnes of H₂ per truck, according to the same JRC report. The latter as well suggests that there are currently no commercial solutions for railway hydrogen transport. However, in late 2022, the German national railway operator Deutsche Bahn suggested transporting large amounts of green hydrogen on trains in order to offer an alternative to still-non-existent hydrogen pipelines, planning to use ammonia as a carrier and cracking it into its components to extract and use the hydrogen (Amelang 2022).

All the above discussed options do not allow for the transport of large amounts of hydrogen comparable to those of natural gas that nowadays cross the globe in form of LNG. The typical size of an LNG tanker (ship) is in the range of 125 000-175 000 m³, but when methane is regasified it acquires around 600 times more volume than LNG. Currently, a prototype for a liquid hydrogen carrier developed by Kawasaki Heavy Industries, the «Suiso Frontier», has been under trial transporting liquefied hydrogen from Australia to Japan with a capacity of 1250 m³ or around 85 tonnes of liquid hydrogen (Kawasaki Heavy Industries Ltd 2019). However, hydrogen is mostly carried through ammonia, which is currently performed on a regular basis and requires partial or full refrigeration (ammonia liquefies at -33°C) in order to keep the ammonia cargo in liquid form around atmospheric pressure (Cebolla et al. 2022). Maritime transport of hydrogen implies also an upgrading of LNG terminals. The latter infrastructures can indeed become entry gates of hydrogen into the EU, since they provide industrial-scale access to maritime logistics, have tanks with large storage capacities ready to work in cryogenic conditions, and direct connection to the gas grid (ENSTO-G et al. 2021). Given the lower temperature (-253°C) required for hydrogen liquefaction compared to natural gas (-160°C), LNG terminals' components need to be replaced, even though the technology itself is not new. In different parts of the world, LH₂ production, handling, and distribution have been performed for over 50 years, and the experience of the LNG industry will be invaluable to build on that existing knowledge (ENTSO-G et al. 2021).

1.2.3 Cost-effectiveness comparison of H₂ transport methods

The economic analysis of hydrogen transportation via new or refurbished pipelines needs to take the levelised cost of transmission (LCOT) into account. The latter – which is reported for the European scenario – can be defined as the discounted cost per MWh of hydrogen transported by the pipeline (European Commission 2021). As summarised in Table 3, while the investment cost for completely new hydrogen pipelines – based on estimations for the German network – would amount to no less than €2.48 million (in 2019 prices) per km of pipeline length and those for a repurposed gas pipeline would be around €0.37 million/km (in 2019 prices), the LCOT for refurbished and newly built pipelines is estimated at around 3.7€/MWh per 600 km and 4.6-45€/MWh/600 km respectively (European Commission 2021). Thus, it can be said that the investment cost of repurposing the existing lines is around 15% of the cost of building new hydrogen pipes, even though there are other studies that report a CAPEX per

km of refurbished hydrogen pipelines equal to around 33% of the cost of newly built lines (ACER 2021). These figures suggest that converting the gas network to carry pure hydrogen can be cheaper than building new infrastructures. However, as mentioned in the previous sub-section, the process of conversion can involve issues with gas supply and should therefore be done gradually, and it should especially consider the developments in hydrogen demand across long distances.

Table 3 – Investment costs [$M\text{€}_{2019}/\text{km}$] and Levelised Cost of Transmission (LCOT) [$\text{€}_{2019}/\text{MWh}/600 \text{ km}$] for new and refurbished hydrogen pipelines. Source: own elaboration from European Commission (2021).

Type of pipeline	Investment costs	LCOT
New	2.48	4.6-45
Refurbished	0.37	3.7

The identification of the different «tipping points» – here understood as the points where one particular method of hydrogen transportation becomes more cost-effective than the one previously used – is useful to put the technologies into perspective and contextualise them in the next chapters. If trucks are seen as the most cost-effective option for H_2 transport in small volumes (less than 10 tonnes per day) over short distances (up to 200 km) (ACER 2021), the cost of MEGC systems is around 790-1100\$/ kg_{H_2} using compressed hydrogen, while beyond a distance of 300/400 km it is more cost-effective to transport liquid H_2 ¹⁴. In terms of shipping routes, while transporting ammonia appears much cheaper than pure hydrogen transport, for distances below 1500 km, transporting hydrogen gas by pipeline is likely to be the cheapest delivery option, and above 1500 km ammonia or LOHC become more cost-effective (IEA 2019). Conversion costs can significantly impact business cases since as much 28% (11kWh/kg) of the transported energy can be consumed during LOHC dehydration and hydrogen separation (ENTSO-G et al. 2021).

Before analysing the current technologies for storing hydrogen, it is interesting to combine the different H_2 transportation methods and assess their cost-efficiency, drawing from Cebolla et al. (2022), who also provide some of the most updated figures in terms of costs. Hydrogen delivery costs (in $\text{€}/\text{kg}_{\text{H}_2}$) are plotted against distance for 1 Mt of H_2 per year in a two-fold scenario: 1) high electricity prices (Figure 4), with a production site electricity price of 50 $\text{€}/\text{MWh}$ and a consumption site price of 130 $\text{€}/\text{MWh}$, and 2) low electricity prices (Figure 5), with a production site electricity price of 10 $\text{€}/\text{MWh}$ and a consumption site electricity price of 50 $\text{€}/\text{MWh}$. While the first price scenario is based on current and 2022-23 electricity prices, the low-price scenario includes future (2030+) estimated renewable electricity price trends. It is important to note that the colour of the background (blue and red for Figure 4, blue, red and green in Figure 5) reflects the cheapest hydrogen transport method for each distance.

¹⁴ Available at: <https://www.energy.gov/eere/fuelcells/doe-technical-targets-hydrogen-delivery>.

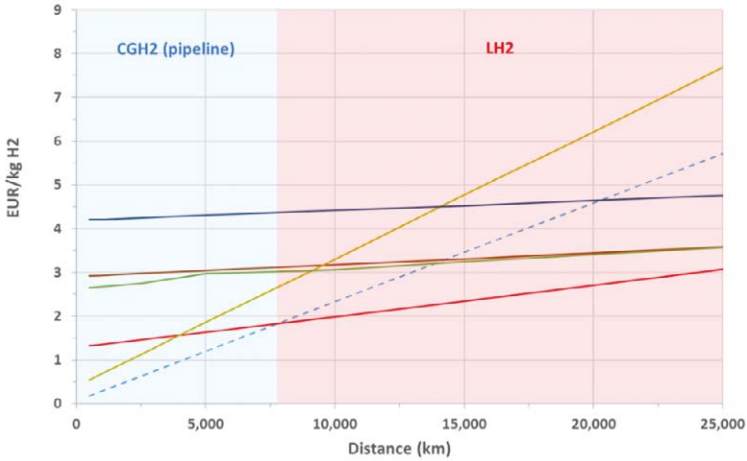

Figure 4 – Hydrogen delivery cost vs. distance (High electricity price)¹⁵. Source: Cebolla et al. (2022).

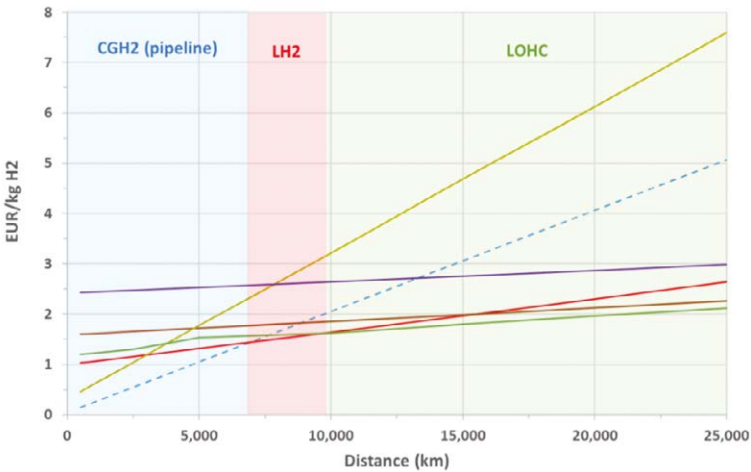

Figure 5 – Hydrogen delivery cost vs. distance (Low electricity price)¹⁶. Source: Cebolla et al. (2022).

For high electricity prices (Figure 4), compressed hydrogen transported in pipelines is the cheapest option up to around 7500 km, whereas for distance be-

¹⁵ On the left-side, from the bottom up, the curves correspond respectively to: Compressed hydrogen in pipelines, Compressed hydrogen in ships, Liquefied hydrogen, LOHC, Ammonia, Methanol.

¹⁶ On the left-side, from the bottom up, the curves correspond respectively to: Compressed hydrogen in pipelines, Compressed hydrogen in ships, Liquefied hydrogen, LOHC, Ammonia, Methanol.

yond 7500 km liquefied hydrogen remains the most cost-effective method, due to the additional costs involved in combining H_2 with the other chemical carriers. In the low electricity price scenario (Figure 5), hydrogen pipelines are the cheapest option up to around 6500 km, after which LH_2 becomes the more economic option. From around 10000 km, LOHC becomes the most cost-effective option, while for very long distances (above 15000 km), ammonia and LOHC (brown and green lines) perform better than LH_2 (red line), mainly due to the issue of boil-off (which imply hydrogen losses during transportation when H_2 is liquefied).

1.2.4 Hydrogen storage technologies

Storage has been insufficiently explored up to this point, and no viable business model for hydrogen – as an internationally or even locally traded commodity – could possibly omit the fact that this substance in most cases will have to be stored at least right after its production and before its delivery to the end user (Patonia and Poudineh 2023). This is especially true with renewable (solar and wind-generated) H_2 , since its generation is intermittent, but its current and projected demand (mainly from industrial customers) is stable. Therefore, while the availability of renewable energy for hydrogen production is subject to strong fluctuations, the operation of pure H_2 networks serving significant hydrogen demand would require the services of highly flexible hydrogen storage (ACER 2021). According to Usman (2022), the practical hydrogen storage is perhaps the biggest hurdle in the success of the hydrogen economy on a large scale.

Given the need to decarbonise the economy, hydrogen storage not only serves final H_2 demand, which will gradually increase in the next decades, but it has become increasingly important to provide for long-term electricity storage when non-dispatchable power sources (such as solar and wind) are used to produce renewable electricity. While batteries, for instance, can absorb short-term renewable electricity fluctuations, hydrogen can allow for larger-scale and longer-term storage mainly through Power-to-Gas (P2G) technologies. Hydrogen contribution will be critical to manage seasonal peaks in the RES electricity demand and supply, due to the projected increase in electrification and overall use of renewables. It will also optimise investments in energy systems by reducing over-investments in electricity grids.

There is however an issue related to the actual efficiency of using electricity to produce hydrogen (by electrolysis), storing the hydrogen, and then converting it back to electricity by using a gas turbine and a power generator, or a fuel cell. Hydrogen re-electrification with these two methods can have efficiencies as high as 50%¹⁷, which means that at least 50% of the energy is lost. Nonetheless, it should not be neglected that the alternative to hydrogen production, storage and re-electrification could be that renewable electricity must be curtailed because

¹⁷ Retrieved from: Energy Storage Association. (n.d.). *Hydrogen Energy Storage*. [online] Available at: <https://energystorage.org/why-energy-storage/technologies/hydrogen-energy-storage/#:~:text=Hydrogen%20Re%2DElectrification>

of the lack of electrolyser capacity to transform the surplus renewable electricity into renewable hydrogen. The efficiency of such a situation would be equal to zero.

It is essential to analyse hydrogen storage technologies along two dimensions: 1) the physical forms or chemical compounds in which hydrogen can be stored, and 2) the sites where H_2 can be placed when needed. The five forms of hydrogen previously addressed will be analysed here to account for their use as storage options. Large- (country-) scale storage of hydrogen is still technologically limited to H_2 compression and injection underground (Patonia and Poudineh 2023). The second form of pure hydrogen (liquefied H_2) presents significant challenges when it is stored, owing to the evaporation of part of this hydrogen – known as «boil-off» – which is a consequence of the heat transfer from the (warmer) storage tank surroundings, to the stored hydrogen (Cebolla et al. 2022). This in turn will imply a pressure increase inside the tank, but not necessarily a loss of hydrogen, since the evaporated H_2 may be redirected back to the liquefaction plant, or to an intermediate gas storage buffer, or directly to a final user (Cebolla et al. 2022). According to the same JRC report, however, these measures require additional equipment and integrated refrigeration and storage (IRAS), thus implying higher costs. The last three options are hydrogen compounds: ammonia (NH_3), which can be stored at cryogenic temperatures at atmospheric pressure; methanol (MeOH), whose storage is usually performed in stainless steel tanks; and LOHC, which can be stored in large quantities at ambient conditions in double-walled containers, as used for crude oil or diesel (Cebolla et al. 2022).

The second dimension of the present analysis concerns hydrogen storage sites, about which there is currently substantial debate in Europe. All the available options can be divided into above ground and underground storage. The former is almost exclusively represented by superficial tanks, containing either compressed or liquefied hydrogen. Compressed hydrogen, however, even at very high pressure (700 bars or 70 Mpa), has only 15% of the energy density of gasoline, so storing the equivalent amount of energy as hydrogen at a vehicle refuelling station, for instance, would require nearly seven times the space (IEA 2019). On the other hand, ammonia has a greater energy density, but it will also lead to greater energy losses due to the required conversion process (IEA 2019). Finally, the costs for large tanks (200-300 tonnes) of liquefied H_2 can range between 150-300 €/kg H_2 (Derking et al. 2019).

Underground hydrogen storage (UHS) can be subdivided into three main types of formations, that provide large-scale seasonal storage: salt caverns, aquifers and depleted fields (ENTSO-G et al. 2021). Other types of underground storage include conventionally mined rock caverns, abandoned mines and also pipe storage, which is located a few meters below ground level and it is not classifiable as geological storage (Kruck et al. 2013)¹⁸. Geological and reservoir constraints, technical and safety limitations, legal barriers, conflicts of interest, and

¹⁸ Gas that is stored within the pipes of a gas transmission or distribution system is known as «line pack», and it is used by gas system operators as a means of balancing the system or meeting

social acceptance are amongst the most significant barriers to the implementation of UHS (Tarkowski and Uliasz-Misiak 2022).

Salt caverns

These sites are suitable for storing pure hydrogen due to their low cushion gas requirement¹⁹, the large sealing capacity of rock salt and the inert nature of salt structures, limiting the contamination of the hydrogen stored (ENTSO-G et al. 2021). Besides, salt caverns offer very flexible H₂ storage (injection) and retrieval but, as can be seen in Figure 6, opportunities for storing hydrogen in salt caverns are geographically limited to a few areas in several EU Member States (ACER 2021). The largest potential is indeed located in the southern part of the North Sea and in its bordering countries. The potential for hydrogen storage in European salt caverns (onshore and offshore) has been estimated at 2.5 billion tonnes of hydrogen, with the largest potential in Germany (42%) (Caglayan et al. 2020)²⁰.

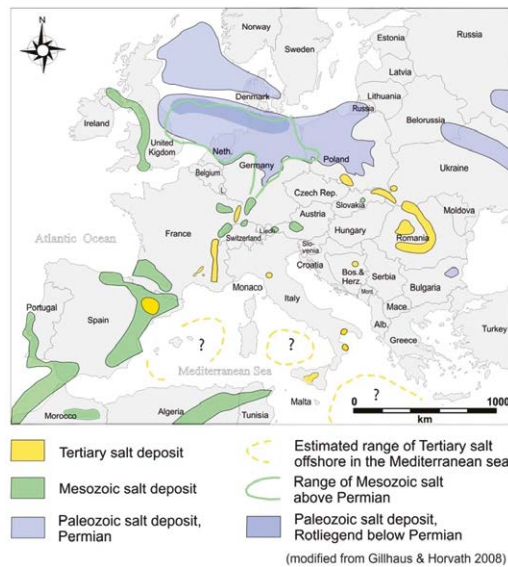

Figure 6 – Salt deposits in Europe. Source: Kruck et al. (2013).

customer demand even when supply delivered to the system on a given day does not match consumption. Retrieved from: <https://www.energyknowledgebase.com/topics/line-pack.asp>

¹⁹ Cushion gas (or base gas) is the volume of natural gas (or hydrogen gas in the case of H₂ storage) intended as permanent inventory in a storage reservoir to maintain adequate pressure and deliverability rates throughout the withdrawal season (Energy Information Administration 2015).

²⁰ Salt caverns can also be employed as fast-cycle storages, meaning that hydrogen can be injected and withdrawn quite rapidly, which can turn out to be a significant asset when hydrogen demand (especially for the industrial sector) will be rather flat compared to seasonal demand of natural gas today.

Aquifers

Such formations are made of porous and permeable rock containing fresh water or brine, and if they are overlain by a layer of impermeable cap rock (e.g. tight shale) they can be used to store gas, but they are rather inflexible to operate (Kruck et al. 2013). In addition, saline water in combination with hydrogen attacks rock, steel, and cement (ACER 2021). This storage option involves higher uncertainties concerning its costs compared to salt caverns, and in most cases the costs are expected to be higher than for the latter and for depleted hydrocarbon fields (Kruck et al. 2013).

Depleted fields

These share the porous rock characteristic with aquifers, except that they were filled with hydrocarbons in the past which have been withdrawn (Kruck et al. 2013). Notwithstanding possible contamination of hydrogen with the hydrocarbons and other gases in the reservoir (ACER 2021), the advantage of depleted fields is that these structures are well known from the time when the reservoir had been explored and tested, and the remaining gas can be used as cushion gas (Kruck et al. 2013). In late April 2023, Austria’s gas storage operator RAG launched the world’s first underground hydrogen storage pilot at a former natural gas reservoir in Rubensdorf, aiming at demonstrating the role that hydrogen can play in seasonal energy storage (Dokso 2023). The pilot project will store 1.2 million m³ of hydrogen (produced by a PEM electrolyser), equivalent to 4.2 GWh of power, thus being used to store excess renewable electricity on the grid. Figure 7 provides the equivalent in TWh of hydrogen storage needs and potential according to the targets of 20 EU countries plus the UK.

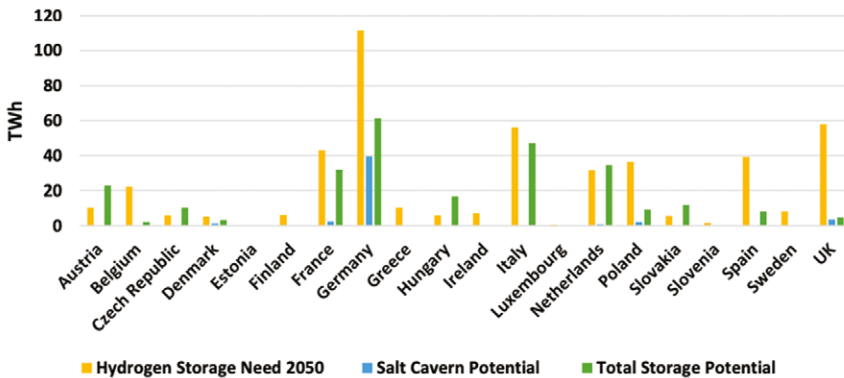

Figure 7 – Estimates of hydrogen storage need by 2050 vs. potential. Source: Cihlar et al. (2021).

The existence of several hydrogen storage technologies implies significant differences in the so called «Levelised cost of storage» (LCOS or LCHS). The

latter is defined as the discounted cost per MWh of H₂ discharged²¹ (European Commission 2021). Hence, when hydrogen is specifically used to store electricity²², the LCOS divides the total cost of this electricity storage technology across its lifetime by its cumulative delivered electricity, describing the minimum revenue required for each unit of discharged energy for the storage project to achieve a net present value (NPV) of zero²³. Following the analysis of the LCOH and LCOT, table 4 outlines the LCOS estimations for the three main underground storage options examined above.

Table 4 – Levelised Cost of Hydrogen Storage for different underground storage options [€/MWh_{H₂}]. Source: own elaboration based on European Commission (2021).

Type of underground storage	LCOS
Salt cavern	17
Depleted gas field (monthly cycle) ²⁴	51-76
Porous rock cavern (bi-annual cycle)	104

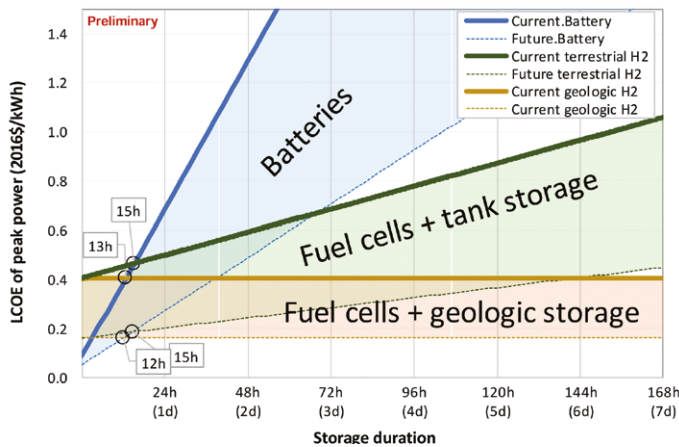

Figure 8 – Economic performance benchmarks for current & future hydrogen and batteries. Source: Penev et al. (2019).

²¹ Energy storage devices (such as hydrogen) are «charged» when they absorb energy, either directly from renewable generation devices or indirectly from the electricity grid, and they “discharge” when they deliver the stored energy back into the grid (EASE 2023).

²² 1 tonne of hydrogen delivers around 33 MWh of electrical energy.

²³ See: Schmidt, O. (n.d.). *Projecting the future lifetime cost of electricity storage technologies*. [online] Storage Lab. Available at: <https://www.storage-lab.com/levelized-cost-of-storage>.

²⁴ The number of times a storage can be fully filled and emptied during a defined period of time is known as «storage cycling rate» (KYOS, 2023).

One last key aspect to consider when dealing with hydrogen as electricity storage is the LCOE (Levelised cost of electricity), which can explain why this molecule can be stored for extended periods of time at very low marginal cost relative to electricity. Figure 8 gives an illustration of the price competitiveness of storing electricity in batteries versus hydrogen storage coupled with fuel cells (to convert H₂ back to electricity). The LCOE (given in \$/kWh) indicates that hydrogen technologies could be more economical than batteries for storage duration beyond 15 hours.

1.3 Hydrogen utilisation

This section aims at completing the analysis on the hydrogen value chain, by outlining the sectors that are and will progressively be most impacted by the use of hydrogen, either after its re-electrification or as a fuel. We deepen the relevant aspects of present and future H₂ demand in the EU countries in the following sectors: industry, transport, buildings, and power generation. While China is the largest hydrogen consumer globally (around 30 million tonnes or 29% of global consumption), the EU accounted for around 8% (7.4 Mt) in 2022, and within the EU the largest H₂ consumer is also its biggest producer, Germany (1.7 Mt) (IEA 2023c). According to Tarvydas (2022), hydrogen usage in end-use sectors will remain negligible in the next decade, but by 2040 and 2050 the EU's H₂ demand could provide between 10 and 20% of final energy demand²⁵.

1.3.1 Industry

Hydrogen will compete with bioenergy and fossils with carbon capture and storage (CCS) in decarbonising hard-to-abate industrial sectors (Tarvydas 2022). One key application where green hydrogen can be introduced is steel-making. The latter industry accounts for 4% of all the CO₂ emissions in Europe and 22% of industrial carbon emissions (Bellona Europa 2021), since the primary steelmaking method involves two fundamentally high-emission steps: first, the iron ore is melted in a blast furnace (at about 2000°C) usually using natural gas or coke (made from coal), thus obtaining so called «pig iron» in a process known as «direct reduction of iron» (DRI); second, the pig iron is made into steel, via a process that can generate up to 1.85 tonnes of CO₂ for every tonne of steel produced (Alverà 2021). When green hydrogen – instead of fossil fuels – is used to reduce the iron ore, the latter is heated between 800-1200°C, obtaining pig iron, which can be then fed into an Electric Arc Furnace (EAF), where electrodes generate a current to melt the pig iron to produce steel (Bellona Europa 2021) with no emissions²⁶. Such a technique has been around at a

²⁵ The implications of the Fit-for-55 ambitions and the REPowerEU Plan's acceleration will be examined in the next chapter.

²⁶ As of November 2022, approximately 24 DRI projects (40 to 50 Mt of DRI capacity) had been announced, being located primarily in Western and Northern Europe (Durinck et al. 2022).

commercial scale since the late 1960s, but not with pure (or green) hydrogen, thus generating emissions.

Although hydrogen (and especially green H₂) costs more than fossil fuels, the existence of a carbon price, such as the EU ETS, can make cleaner alternatives more competitive, not to mention the spike in fossil gas prices, that started in late 2021 and worsened after the beginning of Russia's large-scale invasion of Ukraine in early 2022. According to the European Commission (2021), the investment cost of new hydrogen DRI-EAF based manufacturing capacity is between 400-752 €/tonne of annual steel production capacity, while the steel production costs using the same technology are between 386-685 €/tonne of crude steel.

Besides steelmaking, which is projected to cover most H₂ demand amongst the hard-to-abate sectors by 2050, there are other industries which can potentially scale up their use of this clean molecule. One example is provided by the cement sector, that can use hydrogen either as a fuel in the cement production process (replacing coal and natural gas), or as a means to capture CO₂ and use it as feedstock (carbon capture and utilisation) for the production of other products such as building materials and fuels (Commodity Inside 2023). The same can be done in the ceramics industry, as demonstrated by the agreement between the Italian company Iris Ceramica and the national gas TSO SNAM in late 2021, that aims to fully decarbonise the company's production process through a 100% hydrogen-fuelled plant (Iris Ceramica 2021)²⁷.

1.3.2 Transport

According to Tarvydas (2022), 4% of fuel demand in transport will be met by hydrogen by 2030, rising to 17% and around 27% in 2040 and 2050 respectively. It is however important to distinguish between the different categories of transport, since some of them will see a quicker scale-up of hydrogen-fuelled vehicles while in other types of transport the molecule will remain rather cost-inefficient compared to electricity-powered or alternatively fuelled vehicles. Hydrogen can become the key to decarbonising heavy-duty and long-haul transport, as there are hardly any other zero-emission alternatives available (Ruf 2018). Those categories include maritime and aviation applications, which however remain at a prototyping stage. In the shipping sector, hydrogen fuel cells are used, but only in a few cases are they employed as propulsion. Fuel cells can be used as auxiliary power units for on-board energy needs, while for airplanes, fuel cell-powered flights are not regarded as feasible (Ruf 2018). Hydrogen can rather play a more significant role in the production of e-kerosene (used as a fuel in aviation), which is generated by combining H₂ and CO₂, and is included in the category of the so called «e-fuels» or «power-to-liquid». Two conditions are essential for e-kerosene to have zero greenhouse gas emissions. First, hydrogen needs to be

²⁷ This case will be examined more in detail in Chapter 4 of this work on the Italian hard-to-abate sectors.

produced using renewable electricity, and second, carbon dioxide needs to be captured from the atmosphere (Transport & Environment 2021).

Light and medium-duty transport deserves a separate discussion, as there is currently much debate on the actual cost-effectiveness and maturity levels of fuel-cell cars and hydrogen buses. The former have been introduced in the market but their commercial availability is still limited, and their original equipment manufacturers (OEMs) are almost exclusively located in East Asia (Ruf 2018). Fuel-cell buses are instead a more mature application, mainly for urban areas, even though their technology readiness level (TRL) must take into account the relevant infrastructure needs, such as hydrogen filling stations. These can create bottlenecks and obstacles towards scaling-up hydrogen-powered vehicles²⁸. Hydrogen-fuelled trains also present some criticalities, even though they have been gathering pace to replace conventional diesel trains, as happened in Germany at the Elbe-Weser Railroad Company, which has become the first in the world to operate a fleet of hydrogen trains in regular operation (Weyerer 2022).

1.3.3 Buildings

One of the sectors where the introduction of hydrogen is more discussed – and perhaps most controversial – is the residential sector. The latter is the second largest consumer (behind the transport sector) of final energy in the EU (around 33%) (European Environment Agency 2025) and it is responsible for around 6% of GHG emissions from energy, emitting more than the power sector (Hydrogen Europe 2022). It is important to point out that households use energy for various purposes: mainly space and water heating (around 79% combined), space cooling, cooking, lighting and electrical appliances and other end-uses also outside the dwelling themselves (European Environment Agency 2025). Given that studies investigating the residential applications of hydrogen are still scarce, the use of hydrogen in buildings should be assessed as part of a complete energy system (Rongé and François 2021), not only on the level of a single house, taking into account also the efficiency improvements and renovation of buildings.

Focusing on the main uses of energy in households (heat and power), hydrogen can be used via three main technologies: hydrogen gas boilers, combined heat and power (CHP) units and hybrid heat pumps. The first appliance functions in the same way as a natural gas boiler, even though hydrogen burns with a much higher flame speed, which can generate nitrogen oxides (NO_x, with high global warming potential) during combustion, thus needing a burner re-design (Rongé and François 2021). Controlling these factors while excluding hydrogen for open-flame cooking for which it is not an option, may come at a higher cost and lower fuel efficiency (Korberg et al. 2022). The second technology, CHP,

²⁸ At the end of 2022, the German city of Wiesbaden was forced to retire its ten hydrogen-powered fuel-cell buses - a year after they were delivered - after its publicly owned transport company's €2.3m filling station broke down (Collins 2022).

can be based on either combustion of hydrogen or on fuel cells. The latter system is currently offered by several suppliers in form of «micro-CHP» (in the order of 10s of kW) and they are mostly connected to the natural gas grid and extract the hydrogen from the natural gas (cracking) before feeding it into the fuel cell (Rongé and François 2021). This is only possible where hydrogen-ready infrastructure is already in place, thus recalling the potential issues in repurposing the distribution grid mentioned in the previous section. Finally, hybrid heat pumps are a combination of an air-source heat pump (absorbing heat from outside and releasing it inside) and a gas boiler, with a single control operating the whole system. Hydrogen can be used in the boiler instead of natural gas. Such a technology can help to decarbonise only if hydrogen comes from renewables, which is where most of the sceptical views are concentrated²⁹. In the short term, hydrogen in buildings will remain expensive, mainly due to the lack of infrastructure for distribution and the high investment costs, but after 2030, upscaling of hydrogen supply for the industry will lead to the availability of low cost H₂ for other applications (Rongé and François 2021).

1.3.4 Power Generation and back-up

As reported by the JRC paper on the role of hydrogen in decarbonisation scenarios (Tarvydas, 2022), different studies claim that power generation from hydrogen increases tenfold (compared to 2030), reaching 162 TWh, while the same analyses see around 4-5% of the electricity demand met by hydrogen by 2050. The main issue concerns the RES installed capacity needed to produce the (green) hydrogen that can be reconverted into electricity (a process that currently involves substantial energy losses). For a sustainable power plant, the access to the fuel will be crucial, while the mode of fuel (H₂) transport and distance have a strong impact on costs and distribution emissions. Likewise, the storage volumes and capabilities need viable solutions³⁰. Finally, besides the role hydrogen can play in mitigating seasonal variations in RES production through long-term storage of electricity, fuel cells and hydrogen can also provide for a low-emission alternative as back-up power for critical infrastructures (e.g. data centres, hospitals...) and can provide off-grid power supply for remote areas (Ruf et al. 2018).

1.3.5 The «clean hydrogen ladder»

Finally, we briefly discuss the competition clean hydrogen will have to face to win its way into the economy, as in almost all use cases there can be cheaper, simpler, and safer solutions towards full decarbonisation. The following concepts will take into account the techno-economic aspects of hydrogen use cases,

²⁹ In early 2022, the first smart hydrogen hybrid heating system in the world was demonstrated in the UK, bringing together an H₂ boiler with an electric air-source heat pump (Campbell 2022).

³⁰ See: <https://www.wartsila.com/energy/sustainable-fuels/hydrogen-in-power-generation>.

without considering the push-factor represented by policy support schemes and incentives, that will instead be discussed – at an EU level – in the next chapter. Figure 9 shows the so called «clean hydrogen ladder», which summaries in a simple graphic – based on peer-reviewed research – where clean hydrogen is sure to be part of a net-zero future («unavoidable») and where there are other solutions available («uncompetitive»), along a series of steps on the ladder (red to green). The combination of thermodynamics, micro-, macro-economic, and geopolitical factors within a simple figure can be a double-edged weapon, but it is useful to put all the pieces together. Indeed, the H₂ uses mentioned above, such as steelmaking, long-term electricity storage, long-haul aviation, and shipping, are also in the upper part (future scale-up) of the ladder. Some other uses, such as domestic heating, urban and short-range transport are in the bottom part of the ladder mainly because of the current lack of proper infrastructure (like distribution lines or hydrogen refuelling stations) and thus higher overall costs.

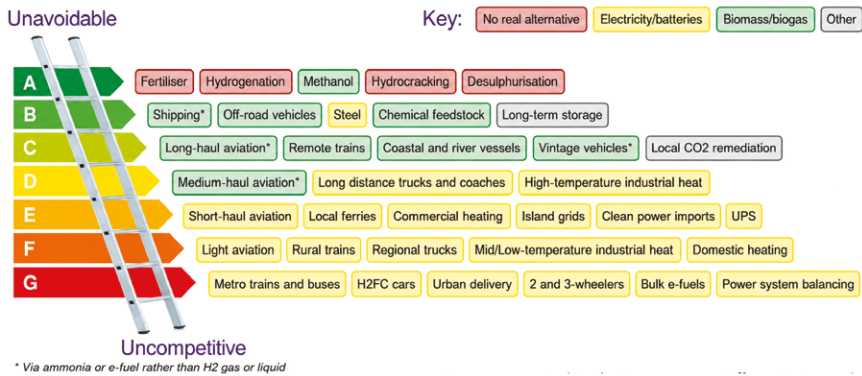

Figure 9 – Clean hydrogen ladder 5.0. Source: Liebreich, M. (2023).

Conclusions

The analysis carried out to identify and discuss the key components of a hydrogen economy (production, transmission, storage systems and end-uses) is a preliminary step to more precisely assess the EU and Italy’s policies aimed at integrating hydrogen into the energy system. As emerged from the examination of H₂ production methods, major political and financial efforts are needed to decarbonise the still largely fossil-based hydrogen generation, while the competitiveness of clean (renewable) hydrogen production depends to a large extent on renewable electricity and electrolyser costs. The focus on the H₂ transmission component has instead exposed the increasingly pressing investment and regulatory challenges related to the creation of a hydrogen infrastructure network, which is currently on the political agenda of both EU institutions and the largest Member States. In addition, the need for greater integration between the gas and power sectors has been made clear by addressing hydrogen storage tech-

nologies, whereby this clean molecule can allow for large-scale and long-term storage mainly through Power-to-Gas (P2G) systems. Finally, one further discussion point concerns hydrogen demand, and thus the still uncertain potential for hydrogen-based end uses.

Two fundamental issues have emerged from the above analysis. The first is strictly related to the cost component, namely the investment irreversibility and the capital indivisibility of grid-based infrastructures and therefore the challenges in planning the transport infrastructure for hydrogen. Investment will have to be increasingly coordinated not only with future H₂ demand, but also with infrastructure development in other sectors. The second issue concerns the effectiveness of producing hydrogen where clean energy sources are cheap and transporting it to the customer, and producing clean electricity to generate hydrogen close to the demand sites.